



Industrial Batteries – Network Power
Classic Solar

Powerful energy storage for photovoltaic systems.

Specifications

Classic EnerSol are robust flooded batteries for energy storage that is proven for use in leisure and consumer applications (SHS). Developed primarily for photovoltaic systems, the EnerSol range stands for:

- Longer design life in cyclic applications in comparison to a standard automotive battery
- Improved DC voltage, due to short intercell connections
- Exceptional anticorrosion property due to thick grid plates
- Internal pocket separators consisting of micro porous glass mat to ensure cell characteristics are retained over full life of the cell
- Terminal adapters can be provided

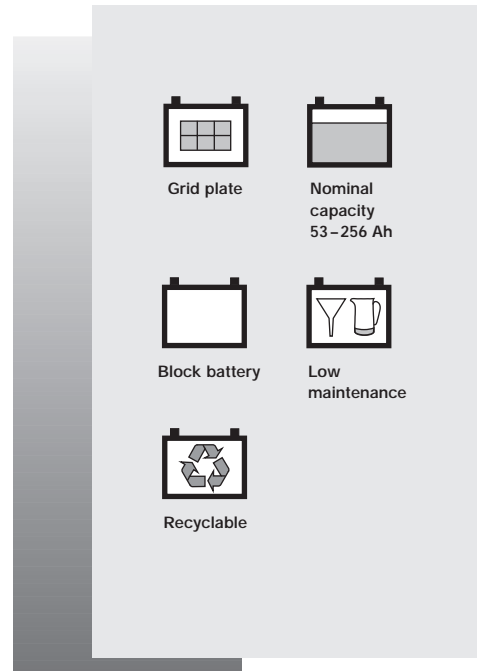

Technical characteristics and data

Type	Part number	Nominal voltage V	Capacity	Nominal capacity	Discharge current I_{120} A	Length (l) max. mm	Width (b/w) max. mm	Height (h) max. mm	Weight including acid approx. kg	Weight acid* approx. kg	Terminal	Terminal position
			C_{100} 1.85 V/C 25°C Ah	C_{120} 1.85 V/C 25°C Ah								
EnerSol 50	NVCE120050WC0TA	12	52	53	0.44	207	175	190	13.6	3.5	A-Terminal	1
EnerSol 65	NVCE120065WC0TA	12	65	66	0.55	246	175	190	17.1	4.6	A-Terminal	1
EnerSol 80	NVCE120080WC0TA	12	78	80	0.66	278	175	190	20.4	5.6	A-Terminal	1
EnerSol 100	NVCE120100WC0TA	12	97	99	0.82	353	175	190	25.2	6.8	A-Terminal	1
EnerSol 130	NVCE120130WC0TA	12	130	132	1.10	348	175	290	35.2	10.0	A-Terminal	2
EnerSol 175	NVCE120175WC0TA	12	175	179	1.49	513	223	223	46.5	12.2	A-Terminal	2
EnerSol 250	NVCE120250WC0TA	12	250	256	2.13	518	276	242	63.0	18.6	A-Terminal	2

*Acid density $d_N = 1.28 \text{ kg/l}$

Data are also valid for dry charged version.

Change „W“ (Wet) to „D“ (Dry)

in the part number

E.g.:

filled and charged NVCE120050 **W** C0TA

dry charged NVCE120050 **D** C0TA

Terminal and torque

Don't use torque for adapter



8 Nm

Drawings with terminal position

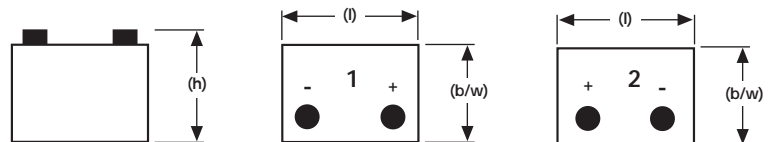

Accessories

EnerSol adapter positive

EnerSol adapter negative

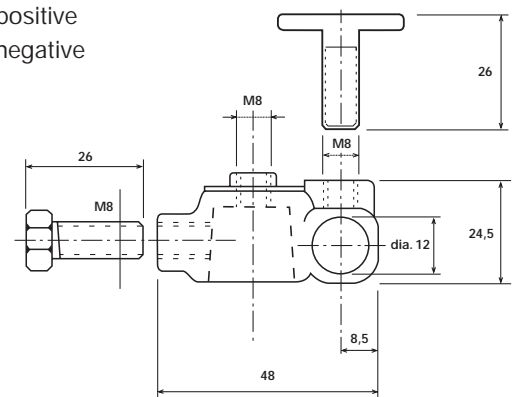

Not to scale!

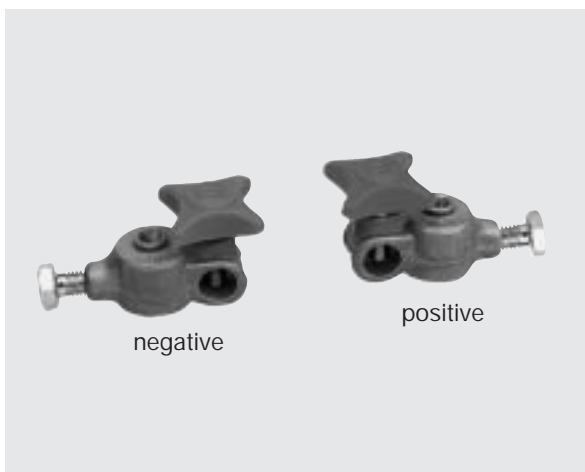







Powerful and universal suitable for every application.

Classic EnerSol T batteries are universal, low maintenance energy supplies for medium industrial solar systems. These lead acid batteries with liquid electrolyte are renowned to be safe and reliable due to their high performance. Typical applications are small solar and wind power systems, holiday and weekend houses.

- Positive tubular plates
- Translucent containers for topping up
- Screw connectors for a better contact and reliability



 Tubular plate	 Nominal capacity 367–1251 Ah	 Single cell
 1500 cycles	 Low maintenance	 Recyclable

Technical characteristics and data

Type	Part number	Nominal voltage	Capacity	Length	Width	Height*	Installed length (B/L)	Weight including acid	Weight acid**	Internal resistance	Short circuit current	Terminal	Pole pairs
			C_{120}	(l)	(b/w)	(h)		approx.	approx.				
			1.85 V/C 25°C Ah	max. mm	max. mm	max. mm	mm	kg	kg	mΩ	A		
EnerSol T 370	NVTS020370WC0FA	2	376	83	198.5	445	93	17.3	5.1	0.701	2900	F-M10	1
EnerSol T 460	NVTS020460WC0FA	2	452	101	198.5	445	111	21.0	6.3	0.561	3625	F-M10	1
EnerSol T 550	NVTS020550WC0FA	2	542	119	198.5	445	129	24.7	7.5	0.467	4350	F-M10	1
EnerSol T 650	NVTS020650WC0FA	2	668	119	198.5	508	129	29.5	8.6	0.450	4500	F-M10	1
EnerSol T 760	NVTS020760WC0FA	2	779	137	198.5	508	147	31.0	10.0	0.386	5250	F-M10	1
EnerSol T 880	NVTS020880WC0FA	2	897	137	198.5	556	147	38.0	11.0	0.438	4660	F-M10	1
EnerSol T 1000	NVTS021000WC0FA	2	1025	155	198.5	556	165	43.1	12.6	0.383	5325	F-M10	1
EnerSol T 1130	NVTS021130WC0FA	2	1154	173	198.5	556	183	47.7	14.1	0.341	5991	F-M10	1
EnerSol T 1250	NVTS021250WC0FA	2	1282	191	198.5	556	201	52.8	15.6	0.307	6657	F-M10	1

*The above mentioned height can differ depending on the used vent(s).

**Acid density $d_N = 1.26 \text{ kg/l}$

Data are also valid for dry charged version.
Change „W“ (Wet) to „D“ (Dry)
in the part number

E.g.:

filled and charged NVTS020370 **W** C0FA

dry charged NVTS020370 **D** C0FA

Capacities in Ah ($C_6 - C_{240}$ at 25°C)

Type	C_6	C_{10}	C_{12}	C_{24}	C_{48}	C_{72}	C_{100}	C_{120}	C_{240}
	1.75 V/C	1.80 V/C	1.80 V/C	1.80 V/C	1.80 V/C	1.80 V/C	1.85 V/C	1.85 V/C	1.85 V/C
EnerSol T 370	260	280	294	333	361	368	369	376	383
EnerSol T 460	327	350	367	416	437	460	444	452	478
EnerSol T 550	393	425	441	499	524	553	533	542	574
EnerSol T 650	492	527	552	625	656	668	647	668	719
EnerSol T 760	574	615	645	729	766	780	755	779	839
EnerSol T 880	654	714	742	840	854	953	869	897	966
EnerSol T 1000	755	809	848	960	1008	1089	993	1025	1104
EnerSol T 1130	850	910	954	1080	1134	1225	1117	1154	1242
EnerSol T 1250	944	1011	1060	1200	1260	1361	1241	1282	1380

The capacities are given at 25°C after 5 cycles.

Drawings with terminal position, terminal and torque

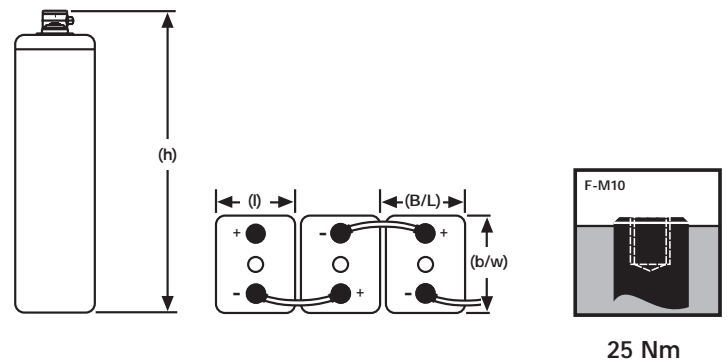

Not to scale!

Energy storage for outstanding power applications.

The Classic OPzS Solar range has been well proven for decades in medium and large power requirements. This energy storage battery is a low maintenance lead acid battery with liquid electrolyte. Due to their robustness, long design life and high operational safety they are ideally suitable for use in solar and wind power stations, telecommunications, power distribution companies, railways and many other safety equipment power supplies.

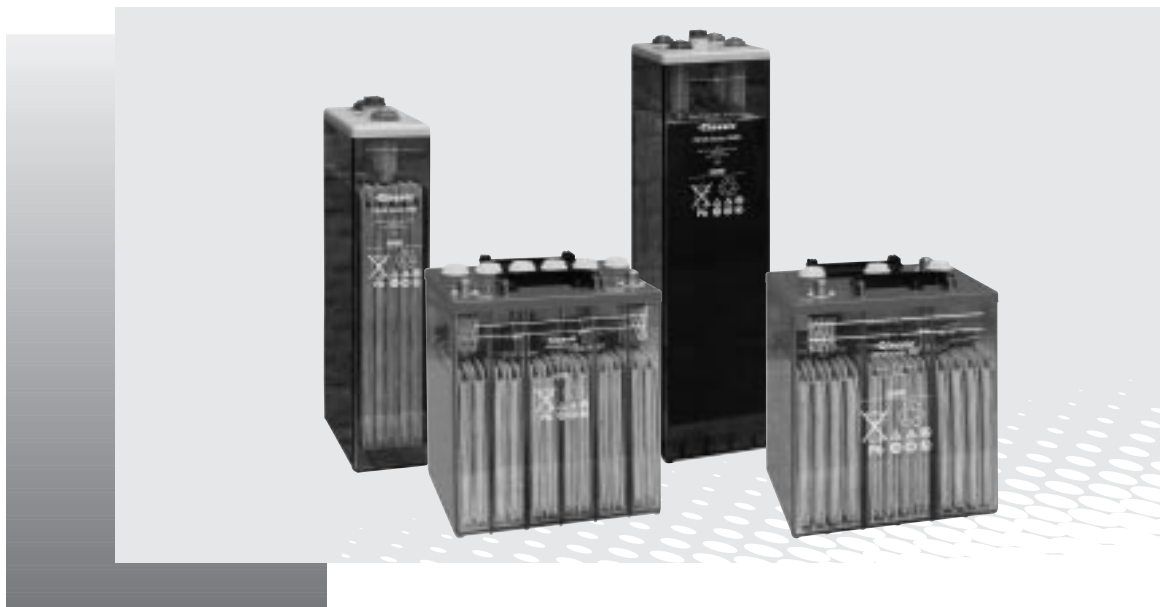

Drawings with terminal position, terminal and torque

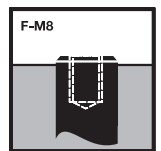
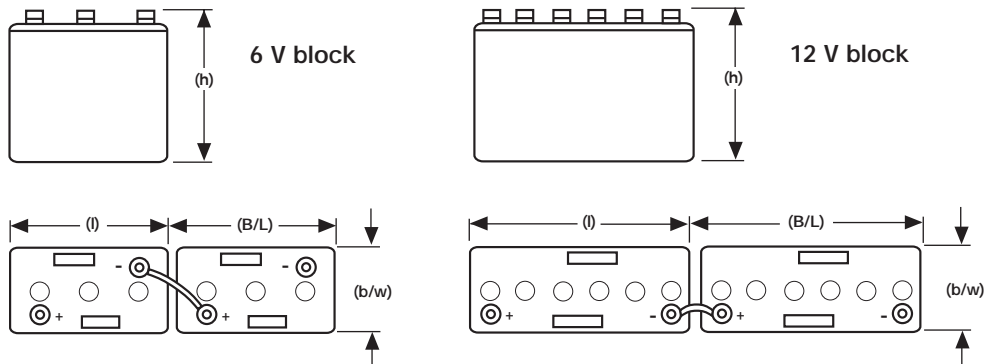

20 Nm

Not to scale!

Technical characteristics and data

Type	Part number	Nominal voltage V	Nominal capacity C ₁₂₀ 1.85 V/C Ah	Length (l)			Installed length (B/L) mm	Weight including acid approx. kg	Weight acid** approx. kg	Internal resistance mΩ	Short circuit current A	Terminal	Pole pairs	Capacities in Ah (C ₆ - C ₂₄₀ at 25°C)								
				max. mm	max. mm	max. mm								C ₆ 1.75 V/C	C ₁₀ 1.80 V/C	C ₁₂ 1.80 V/C	C ₂₄ 1.80 V/C	C ₄₈ 1.80 V/C	C ₇₂ 1.80 V/C	C ₁₀₀ 1.85 V/C	C ₁₂₀ 1.85 V/C	C ₂₄₀ 1.85 V/C
Block																						
OPzS Solar 70	NVSL120070WCOFA	12	70	275	208	385	285	35	15	18.18	688	F-M8	1	55.0	51.5	63.7	69.4	78.4	79.8	81.0	82.7	92.9
OPzS Solar 140	NVSL120140WCOFA	12	140	275	208	385	285	45	14	9.26	1314	F-M8	1	95.4	103.0	108.2	118.7	141.6	145.2	136.0	139.9	162.3
OPzS Solar 210	NVSL120210WCOFA	12	210	383	208	385	393	64	19	6.46	1884	F-M8	1	131.4	154.5	162.0	177.7	206.0	217.8	203.9	210.1	234.1
OPzS Solar 280	NVSL060280WCOFA	6	280	275	208	385	285	41	13	2.68	2283	F-M8	1	203.4	206.0	229.3	250.8	296.2	304.9	287.0	294.0	338.3
OPzS Solar 350	NVSL060350WCOFA	6	350	383	208	385	393	56	20	2.39	2800	F-M8	1	245.5	257.5	284.0	311.5	374.2	383.7	355.0	364.1	424.5
OPzS Solar 420	NVSL060420WCOFA	6	420	383	208	385	393	63	20	1.96	3106	F-M8	1	284.3	309.0	322.9	354.6	420.8	432.6	408.0	417.7	482.9
Cell																						
OPzS Solar 190	NVSL020190WCOFA	2	190	105	208	405	115	13.7	5.2	1.45	1400	F-M8	1	122	132	134	145	165	175	185	190	200
OPzS Solar 245	NVSL020245WCOFA	2	245	105	208	405	115	15.2	5.0	1.05	1950	F-M8	1	159	173	176	190	215	230	240	245	260
OPzS Solar 305	NVSL020305WCOFA	2	305	105	208	405	115	16.6	4.6	0.83	2450	F-M8	1	203	220	224	240	270	285	300	305	320
OPzS Solar 380	NVSL020380WCOFA	2	380	126	208	405	136	20.0	5.8	0.72	2850	F-M8	1	250	273	277	300	330	350	370	380	400
OPzS Solar 450	NVSL020450WCOFA	2	450	147	208	405	157	23.3	6.9	0.63	3250	F-M8	1	296	325	330	355	395	420	440	450	470
OPzS Solar 550	NVSL020550WCOFA	2	550	126	208	520	136	26.7	8.1	0.63	3250	F-M8	1	353	391	398	430	480	515	540	550	580
OPzS Solar 660	NVSL020660WCOFA	2	660	147	208	520	157	31.0	9.3	0.56	3650	F-M8	1	422	469	477	515	575	615	645	660	695
OPzS Solar 765	NVSL020765WCOFA	2	765	168	208	520	178	35.4	10.8	0.50	4100	F-M8	1	492	546	555	600	670	710	750	765	805
OPzS Solar 985	NVSL020985WCOFA	2	985	147	208	695	157	43.9	13.0	0.47	4350	F-M8	1	606	700	710	770	860	920	970	985	1035
OPzS Solar 1080	NVSL021080WCOFA	2	1080	147	208	695	157	47.2	12.8	0.43	4800	F-M8	1	669	773	784	845	940	1000	1055	1080	1100
OPzS Solar 1320	NVSL021320WCOFA	2	1320	215	193	695	225	59.9	17.1	0.30	6800	F-M8	2	820	937	950	1030	1150	1230	1295	1320	1385
OPzS Solar 1410	NVSL021410WCOFA	2	1410	215	193	695	225	63.4	16.8	0.27	7500	F-M8	2	888	1009	1024	1105	1225	1305	1380	1410	1440
OPzS Solar 1650	NVSL021650WCOFA	2	1650	215	235	695	225	73.2	21.7	0.26	7900	F-M8	2	1024	1174	1190	1290	1440	1540	1620	1650	1730
OPzS Solar 1990	NVSL021990WCOFA	2	1990	215	277	695	225	86.4	26.1	0.23	8900	F-M8	2	1218	1411	1430	1550	1730	1850	1950	1990	2090
OPzS Solar 2350	NVSL022350WCOFA	2	2350	215	277	845	225	108.0	33.7	0.24	8500	F-M8	2	1573	1751	1770	1910	2090	2200	2300	2350	2470
OPzS Solar 2500	NVSL022500WCOFA	2	2500	215	277	845	225	114.0	32.7	0.22	9300	F-M8	2	1667	1854	1875	2015	2215	2335	2445	2500	2600
OPzS Solar 3100	NVSL023100WCOFA	2	3100	215	400	815	225	151.0	50.0	0.16	12800	F-M8	3	2080	2318	2343	2520	2755	2910	3040	3100	3250
OPzS Solar 3350	NVSL023350WCOFA	2	3350	215	400	815	225	158.0	48.0	0.14	14600	F-M8	3	2268	2524	2550	2740	2985	3135	3280	3350	3520
OPzS Solar 3850	NVSL023850WCOFA	2	3850	215	490	815	225	184.0	60.0	0.12	17000	F-M8	4	2592	2884	2915	3135	3430	3615	3765	3850	4040
OPzS Solar 4100	NVSL024100WCOFA	2	4100	215	490	815	225	191.0	58.0	0.11	17800	F-M8	4	2775	3090	3125	3355	3650	3840	4000	4100	4300
OPzS Solar 4600	NVSL024600WCOFA	2	4600	215	580	815	225	217.0	71.0	0.11	18600	F-M8	4	3099	3451	3490	3765	4100	4300	4500	4600	4850

*The above mentioned height can differ depending on the used vent(s).

**Acid density $d_N = 1.24 \text{ kg/l}$

Data are also valid for dry charged version.
Change „W“ (Wet) to „D“ (Dry)
in the part number.
E.g.:
filled and charged NVSL120070 W COFA
dry charged NVSL120070 D COFA

Drawings with terminal position, terminal and torque

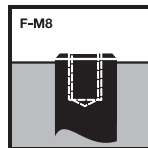

20 Nm

OPzS Solar 190
up to
OPzS Solar 1080

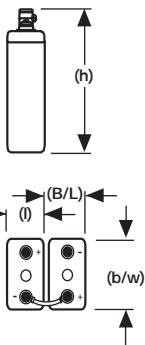

OPzS Solar 1320
up to
OPzS Solar 2500

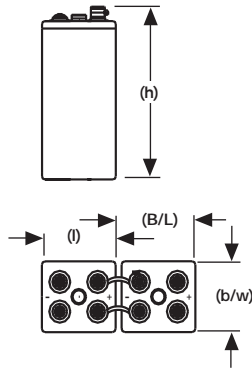

OPzS Solar 3100
OPzS Solar 3350

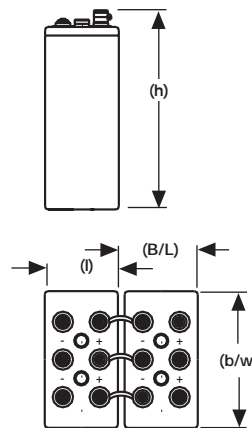

OPzS Solar 3850
up to
OPzS Solar 4600

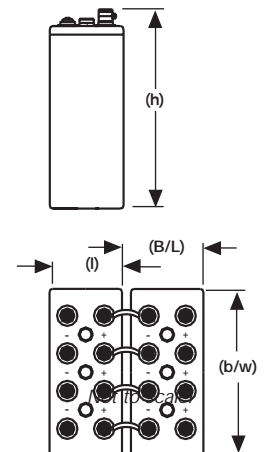

Not to scale!